

## LIST OF ORES AND THEIR NAMES

### SULPHIDE ORE

PbS	→	Galena
HgS	→	Cinnabar
ZnS	→	Zinc blende
Cu <sub>2</sub> S	→	Copper glance
CuFeS <sub>2</sub>	→	Copper Pyrites (Chalcopyrite)
FeS <sub>2</sub>	→	Iron pyrites or Fool's gold
Ag <sub>2</sub> S	→	Silver glance or Argentite
Cu <sub>2</sub> S.Ag <sub>2</sub> S	→	Copper silver glance
Ag <sub>2</sub> S.Sb <sub>2</sub> S <sub>3</sub>	→	Pyrargirite or Rubisilver

### HALIDE ORE

NaCl	→	Rock Salt
KCl	→	Sylvine
CaF <sub>2</sub>	→	Fluorspar
Na <sub>3</sub> AlF <sub>6</sub>	→	Cryolite
AgCl	→	Horn Silver
KCl.MgCl <sub>2</sub> .6H <sub>2</sub> O	→	Carnalite

### OXIDE ORE

Fe <sub>2</sub> O <sub>3</sub>	→	Haematite
Fe <sub>3</sub> O <sub>4</sub>	→	Magnetite
Al <sub>2</sub> O <sub>3</sub> .2H <sub>2</sub> O	→	Bauxite
Fe <sub>2</sub> O <sub>3</sub> .3H <sub>2</sub> O	→	Limonite
Cu <sub>2</sub> O	→	Cuprite or Ruby copper
MnO <sub>2</sub>	→	Pyrolusite
SnO <sub>2</sub>	→	Tinstone or Casseterite
TiO <sub>2</sub>	→	Rutile
Fe.Cr <sub>2</sub> O <sub>4</sub>	→	(FeO + Cr <sub>2</sub> O <sub>3</sub> ) Chromite ore
Na <sub>2</sub> B <sub>4</sub> O <sub>7</sub> .10H <sub>2</sub> O	→	Borax or Tincal
Ca <sub>2</sub> B <sub>6</sub> O <sub>11</sub> .5H <sub>2</sub> O	→	Colemanite
U <sub>3</sub> O <sub>8</sub>	→	Pitch Blende

$\text{FeO} \cdot \text{TiO}_2$	→	Ilmenite
$\text{ZnO}$ (Philosophers wool)	→	Zincite
$3\text{BeO} \cdot \text{Al}_2\text{O}_3 \cdot 6\text{SiO}_2$	→	Beryl

## OXY SALT ORE

### (1) Carbonate Ore :

$\text{CaCO}_3$	→	Lime stone
$\text{MgCO}_3$	→	Magnesite
$\text{CaCO}_3 \cdot \text{MgCO}_3$	→	Dolomite
$\text{FeCO}_3$	→	Siderite
$\text{ZnCO}_3$	→	Calamine
$\text{Cu}(\text{OH})_2 \cdot \text{CuCO}_3$	→	Malachite or Basic Copper Carbonate
$\text{Cu}(\text{OH})_2 \cdot 2\text{CuCO}_3$	→	Azurite
$\text{PbCO}_3$	→	Cerrusite
$\text{SrCO}_3$	→	Strontianite

### (2) Sulphate ore :

$\text{CaSO}_4 \cdot 2\text{H}_2\text{O}$	→	Gypsum
$\text{MgSO}_4 \cdot 7\text{H}_2\text{O}$	→	Epsom Salt
$\text{PbSO}_4$	→	Anglesite
$\text{BaSO}_4$	→	Baryte
$\text{Na}_2\text{SO}_4 \cdot 10\text{H}_2\text{O}$	→	Glauber Salt
$\text{SrSO}_4$	→	Celestine
$\text{K}_2\text{SO}_4 \cdot \text{Al}_2(\text{SO}_4)_3 \cdot 24\text{H}_2\text{O}$	→	Potash Alum

### (2) Nitrate ore :

$\text{KNO}_3$	→	Indian Salt peter
$\text{NaNO}_3$	→	Chile Salt peter

# METALLURGY

## 1. INTRODUCTION

### Metallurgy

The branch of chemistry which deals with the method of extraction of metals from their ores.

### Metal

The element which tends to form positive ion is called a metal.

### Minerals

The various compounds of metals which occur in the earth's crust and are obtained by mining are called minerals. In earth crust order of abundance of elements is.  $O > Si > Al > Fe$

A mineral may be single compound or a mixture of compounds having fixed chemical composition.

### Ore

The mineral from which a metal can be profitably and easily extracted is called an ore.

### Gangue or matrix

The undesirable impurities present in an ore are called gangue.

### Mining process

Process of taking out ore from earth crust is called mining.

## 2. TYPES OF METALLURGY

(a) **Pyro metallurgy** : Extraction of metal from ore by using heat energy.

Steps involved are : Calcination, roasting, reduction etc.

**Ex.** Less reactive metals : Cu, Fe, CO, Ni, Zn, Sn, Pb etc.

(b) **Hydro metallurgy** : (Ag, Au, Cu) – This is wet metallurgy process.

$Cu \longrightarrow Pyro + Hydro$

Ag and Au  $\longrightarrow$  By cyanide process.

Steps are : (i) Complex formation      (ii) Metal displacement



(Sodium argento cyanide)

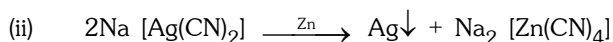

(Impure)

(c) **Electrical metallurgy** : This process used for highly electro positive metal (s-block and A/l) metal obtained by electrolysis of fused salt/anhydrous medium.

(d) **Ion exchange metallurgy** : Trans-Uranic (elements after Uranium in periodic table) elements are obtained by this method.

## 3. STEPS INVOLVED IN THE EXTRACTION OF METALS

The extraction of a metal from its ore is completed in the following four steps.

(a) Crushing and grinding      (b) Pulverisation      (c) Concentration of the ore

(d) Reduction to the metal      (e) Refining of the metal.

## 4. CONCENTRATION OF THE ORE

The removal of impurities from the ore is called its concentration. It is carried out in one or more of the following steps. These undesired impurities are gangue or matrix.

### ***By physicals separation***

#### (a) **Gravity separation (Lavigation)**

This method of concentration of the ore is based on the difference in the specific lavigation gravities of the ore and the gangue particles.

Powdered ore is agitated with a running stream of water. The lighter gangue particles are taken away by water while heavier ore particles settle down. **Ex.** Oxygenated Ores.

#### (b) **Froth Floatation method**

This method is mainly employed for the concentration of sulphide ores.

The method is based on the different wetting characteristics of the gangue and the sulphide ore with water and oil. The gangue preferentially wetted by water and the ore by oil.

The crushed ore along with water is taken in a floatation cell. Various substances are added depending on the nature of the ore and a current of air is blown in. The substances added are usually of three types.

##### (i) **Frothers**

They generate a stable froth which rises to the top of the tank. Example of frother is pine oil, Eucalyptus oil, etc.

##### (ii) **Collectors or floating agents**

These attach themselves by polar group to the grains of the ores which then become water repellent and pass on into the froth. Example: sodiummethyl /ethyl xanthate.

##### (iii) **Activators or Depressants**

These reagents activate or depress the flotation properly and help in the separation of different sulphide ores present in a mixture.

An example of depressant is NaCN. An activator is  $\text{CuSO}_4$ .

#### (c) **Magnetic separation**

If the ore and not the gangue or the gangue and not the ore is attracted by a magnet, the two can be separated by this method.

Magnetite ( $\text{Fe}_3\text{O}_4$ ) is concentrated by this method, ( $\text{FeWO}_4$ ) wolframite removed from  $\text{SnO}_2$ , FeO removed from chromite ( $\text{FeCr}_2\text{O}_4 \Rightarrow \text{Cr}_2\text{O}_3 \cdot \text{FeO}$ ).

### ***By Chemical separation***

Some of the ores are concentrated by means of chemical treatment.

**Leaching** : It involves the treatment of the ore with a suitable reagent. as to make it soluble while impurity remain insoluble. The ore is recovered from the solution by suitable chemical method.

#### (i) **Bayer's process**

Ex. Bauxite ore contain impurity  $\text{Fe}_2\text{O}_3$ ,  $\text{TiO}_2$ ,  $\text{SiO}_2$  when it dissolve in aq. NaOH/pressure + 150 C T bauxite is dissolve but other are not dissolve.

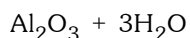
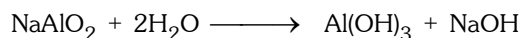
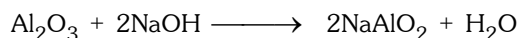

#### (ii) **Cyanide process** : Their process used for Au, Ag by (Mac-Arthur forrest cyanide process).

## CALCINATION

Calcination is a process in which ore is heated, generally in the **absence of air**, to expel water from a hydrated oxide or carbon dioxide from a carbonate at temperature below their melting points.

### **For Example**

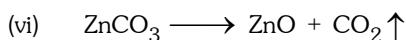
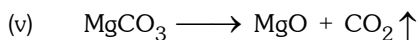
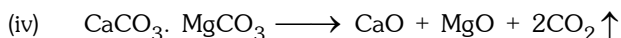
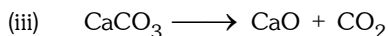
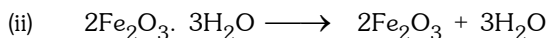
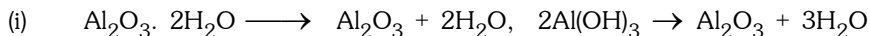

### **Advantages of Calcination**

- (i) Moisture is removed.
- (ii) Organic matter is destroyed
- (iii) The hydroxide and carbonates ores are converted into their oxides.
- (iv) The metal become porous and easily workable

## **6. ROASTING**

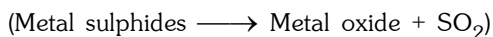

The removal of the excess sulphur contained in sulphide ores by heating **in an excess of air** is called roasting.

The concentrated sulphide ore is heated in reverberatory furnace, below its melting point or fusion temperature in the presence of an excess of air with or without the addition of an external substance.

In roasting definite chemical like oxidation, chlorination etc. take place but in calcination does not occur any major chemical changes.

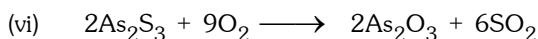
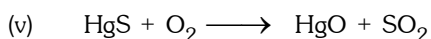
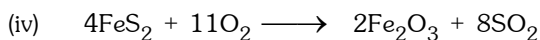
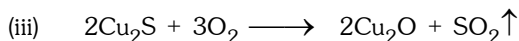
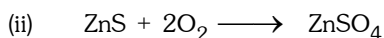
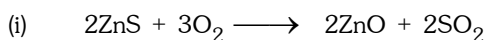

### **Advantages of Roasting**

- (i) Excess of sulphur is removed as volatile oxide.

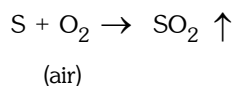

- (ii) The metal sulphide is converted into metal oxide.
- (iii) Impurities of arsenic and antimony are removed as their volatile oxides.

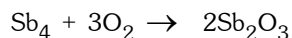

## Type of Roasting

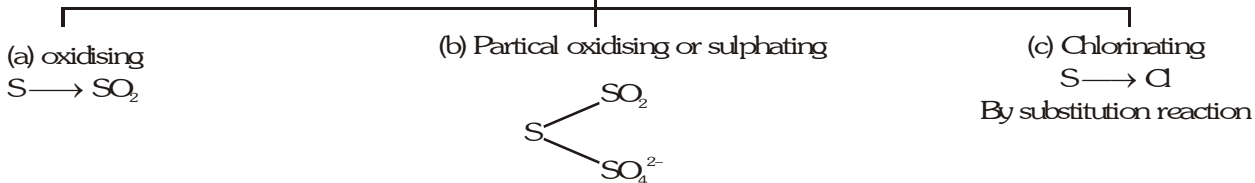

In partial roasting process : In PbS or ZnS



## 7. REDUCTION OF ORE TO THE METAL

The calcined or roasted ore is then reduced to the metallic state in either of the following ways.

(a) **Reduction by carbon (Smelting)** : (This is common method of reduction)

"Reduction of the oxide with carbon at high temperature is known as smelting".

The oxides of less electropositive metals like Pb, Zn, Fe, Sn, Cu etc. are reduced by strongly heating them with coal or coke, in the blast furnace.

**Slag** : Fusible material during reduction process.

**Slag** : Gangue + substance (for remove gangue)

**Fluxes** : Substance used for removing gangue

**Fluxes acidic** : Borax,  $SiO_2$  (remove basic impurity)

**Fluxes basic** :  $MgO$ ,  $MgCO_3$ ,  $CaCO_3$  (remove acidic impurity)

### Smelting

• Concentrate ore (ore + gangue) + RA (carbon) + Flux (RA  $\Rightarrow$  Reducing agent)



•  $\left. \begin{matrix} Cr_2O_3 \\ Mn_3O_4 \\ MnO_2 \end{matrix} \right\} \longrightarrow$  Carbon is not used for reduction

• Coke is not used for reduction of s-block oxide  $Al_2O_3$  (due to formation of metal carbides)

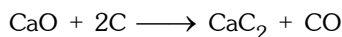

### Some reactions

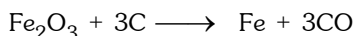
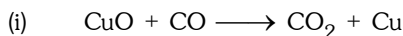

(ii) (gangue) acidic impurity (flux) (slag)

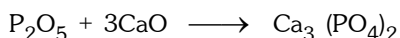
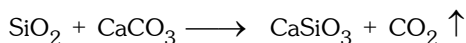

(iii) Basic impurity + Flux  $\longrightarrow$  slag

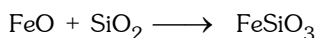
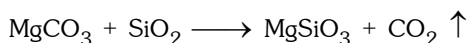

**Note** :- Blue flame is obtained by burning of CO in smelting process

**(b) Self reduction**

Compounds of certain metals are reduced to metal without using any additional reducing agent. ores of Cu, Pb, Hg etc.

Their sulphide ores are partially roasted to give some oxide. This oxide is now reduced to the metal by the remaining sulphide ore at elevated temperatures in the absence of air. The process is known as self reduction.

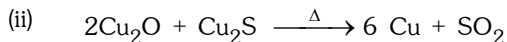
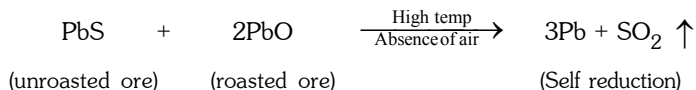
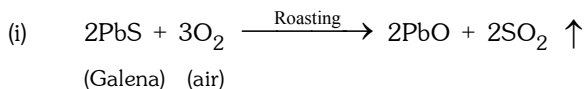
**Self reduction for Pb****(c) Metal displacement method**

In this method, a water soluble compound is obtained from the ore. The aqueous solution of the compound is reacted with a more electropositive metal which displaces, the metal from the solution.

(i) Zairvogel process for silver.

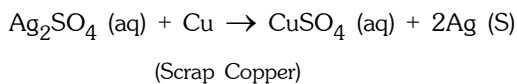
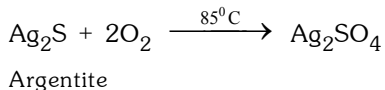

(ii) Separation Ag by Complex formation (Cyanide process)

Silver and gold are extracted by a method involving complex formation.

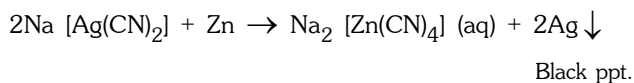
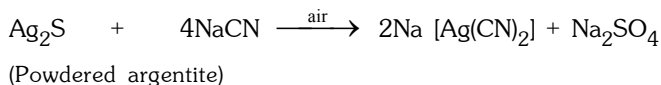
**(d) Electrolytic reduction**

This process is mainly used for the extraction of **highly electropositive metals**.

Electrolysis is carried out in a large cells and a small amount of another suitable electrolyte is added which:

- (i) Lowers the melting point of the main electrolyte
- (ii) Enhances its conductivity
- (iii) Reduces corrosion troubles

**Ex.** Na, K, Mg, Ca, Al, etc.

e.g. Manufacture of metallic sodium (Down's process)

Molten NaCl containing a little  $\text{CaCl}_2$  is electrolyzed between graphite anode and iron cathode. The various reactions that take place are

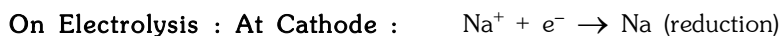

(Metallic sodium)

(e) **Reduction by Al**

This process is employed in the case of those metals which have very high melting points and are to be extracted from their oxides

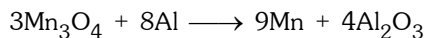
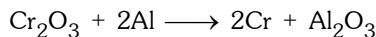

## 8. REFINING OF METALS

Metals obtained by the reduction of its compound still contains some objectionable substance and have to be refined.

Depending upon the nature of the metal and impurities, the following methods are used for purification of the metals.

(a) **Liquation**

This method is used for the refining of metals having low melting point and are associated with high melting impurities.

**Ex.** Pb, Sn, Sb, Bi and Hg.

The impure metal is heated on the sloping hearth of a furnace.

The pure metal flows down leaving behind the non- fusible material on the hearth.

(b) **Distillation**

Metals having low boiling point are refined by this method, for example, zinc, cadmium and mercury.

(c) **Distribution method**

The **parke's process** is used for the desilverization of argentiferous lead ( $\text{PbS} + 0.01$  to  $1\%$  Ag) is based on distribution principle. The principle follows as

- Molten zinc and molten lead form a two phase system.
- Silver is more soluble in molten zinc than the molten lead.
- The Zn - Ag alloy is lighter than Pb and freezes fast.
- The floating solidified Zn - Ag alloy can be easily removed from molten Pb.
- From Zn - Ag alloy, zinc is separated by distillation.

(d) **Zone refining or fractional crystallisation**

Metals of very high purity are obtained by zone refining.

This refining method is based on the fact that impurities tend to remain dissolved in molten metal.

**Ge, Si and Ga** used as semiconductors are refined in this manner.

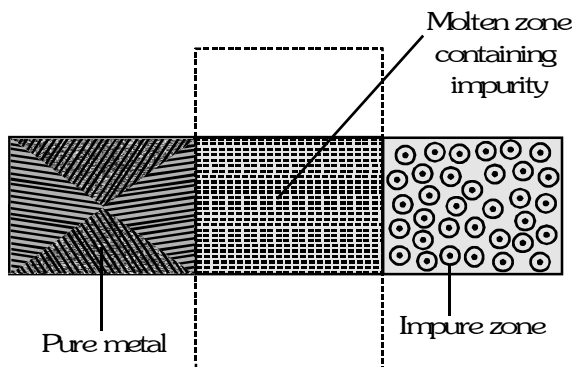



(e) **Oxidation Process (Pyrometallurgical oxidation process)**

These processes are used for refining of metals associated with impurities having high affinity for oxygen than the metal itself.

**Cupellation, pudding and bessemerization** are important oxidation processes employed for refining different metals.

(f) **Electro-refining of Metals**

Metals such as Cu, Ag, Zn, Sn, Pb, Al, Ni, Cr are refined by this method.

The impure metal is made the anode of a electrolytic cell, while cathode is thin plate of pure metal.

Electrolyte is the solution of a double salt of the metal.

On passing the electric current pure metal from the anode dissolves and gets deposited at the cathode.

The soluble impurities go into the solution while insoluble or less electropositive impurities settle down below the anode as **anode mud** or sludge. **Ex.**

**Electrorefining of Copper**

Anode : Blister copper (98%)

Cathode : Pure copper

Electrolyte : An aqueous solution of  $\text{CuSO}_4$  (15% + 5% dil  $\text{H}_2\text{SO}_4$ )

**Electrorefining of Pb (Bett's process)**

Anode : Impure lead., Cathode : Pure lead.

Electrolyte : A mixture of  $\text{PbSiF}_6$  and  $\text{H}_2\text{SiF}_6$

(g) **Vapour phase refining**

(i) **Van - Arkel process**

- Employed to get metal in very pure form of small quantities.
- In this method, the metal is converted into a volatile unstable compound (e.g.iodide), and impurities are not affected during compound formation.
- The compound thus obtained is decomposed to get the pure metal.
- Employed for purification of metals like **titanium(Ti)** and **zirconium(Zr)**.

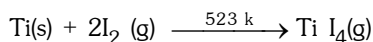

Impure

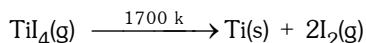

(ii) **Mond's process**

Nickel is purified by using CO gas. This involves the formation of nickel tetracarbonyl.



(h) **Some other methods**

(i) **Kroll collen process**

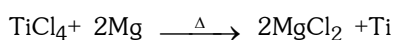

(ii) **IMI method**

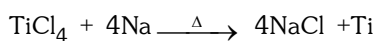

(iii) **Amalgamation process**

For nobel metal Au, Ag from the native ore.

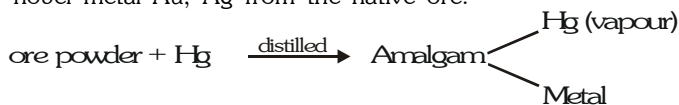

**(A) Extraction of Copper**

Copper is mainly extracted from copper pyrites. After the concentration of its ore by froth flotation process, the ore is roasted in a current of air to remove arsenic, antimony and much of sulphur. The reactions occurring are

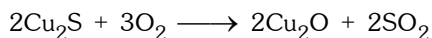
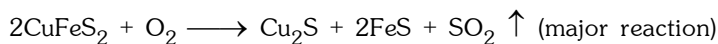

The ore is then mixed with a little coke and sand and smelted in a water-jacketed blast furnace. The minor reactions that occurred during roasting continue here. Ferrous oxide combines with sand to form a fusible slag. Cuprous oxide formed combines with ferrous sulphide to give ferrous oxide and cuprous sulphide. This is because iron has more affinity for oxygen than copper.



Molten mass collected from the bottom of furnace contains largely cuprous sulphide and a little ferrous sulphide. This molten mass is known as matte.

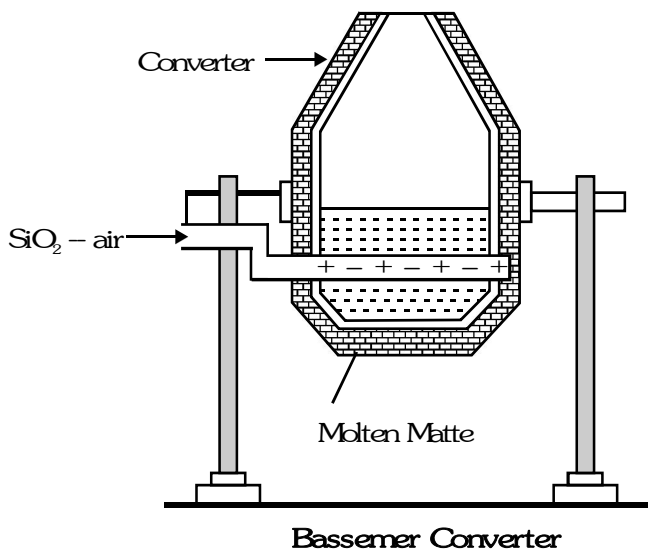

The molten matte is finally transferred to Bessemer converter. A blast of sand and air is blown in the converter through tuyeres which are situated a little above the bottom. This causes removal of S and As oxides and ferrous oxide as slag. At the same time  $\text{Cu}_2\text{S}$  is oxidized mostly into  $\text{Cu}_2\text{O}$  and partly into  $\text{CuO}$  and  $\text{CuSO}_4$ . All these react with  $\text{Cu}_2\text{S}$  giving copper. The reactions are

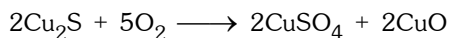
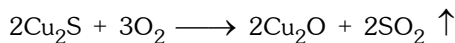

Finally, copper may be refined electrolytically (electrolyte; copper sulphate : anode; impure copper and cathode; pure copper).

**(B) Extraction of lead**

Lead is mainly extracted from galena. After the concentration of the ore by froth flotation process, the ore is roasted in a reverberatory furnace for about six hours at a moderate temperature in a current of air. Part of galena is converted into lead oxide and lead sulphate. After this, the supply of air is stopped and small quantities of carbon, quicklime and cheap iron ore are added along with increase of temperature.



The obtained lead contains impurities such as Cu, Ag, Bi, Sb and Sn. Silver is removed by Parke's process where molten zinc is added to molten impure lead. The former is immiscible with the latter. Silver is more soluble in molten zinc than in molten lead. Zinc-silver alloy solidifies earlier than molten lead and thus can be separated. After this, crude lead is refined electrolytically (Electrolyte; lead silicofluoride,  $\text{PbSiF}_6$  and hydrofluosilicic acid,  $\text{H}_2\text{SiF}_6$  with a little gelatin, anode, crude lead and cathode; pure lead).

### (C) Extraction of Iron

#### FLOW SHEET FOR EXTRACTION OF IRON

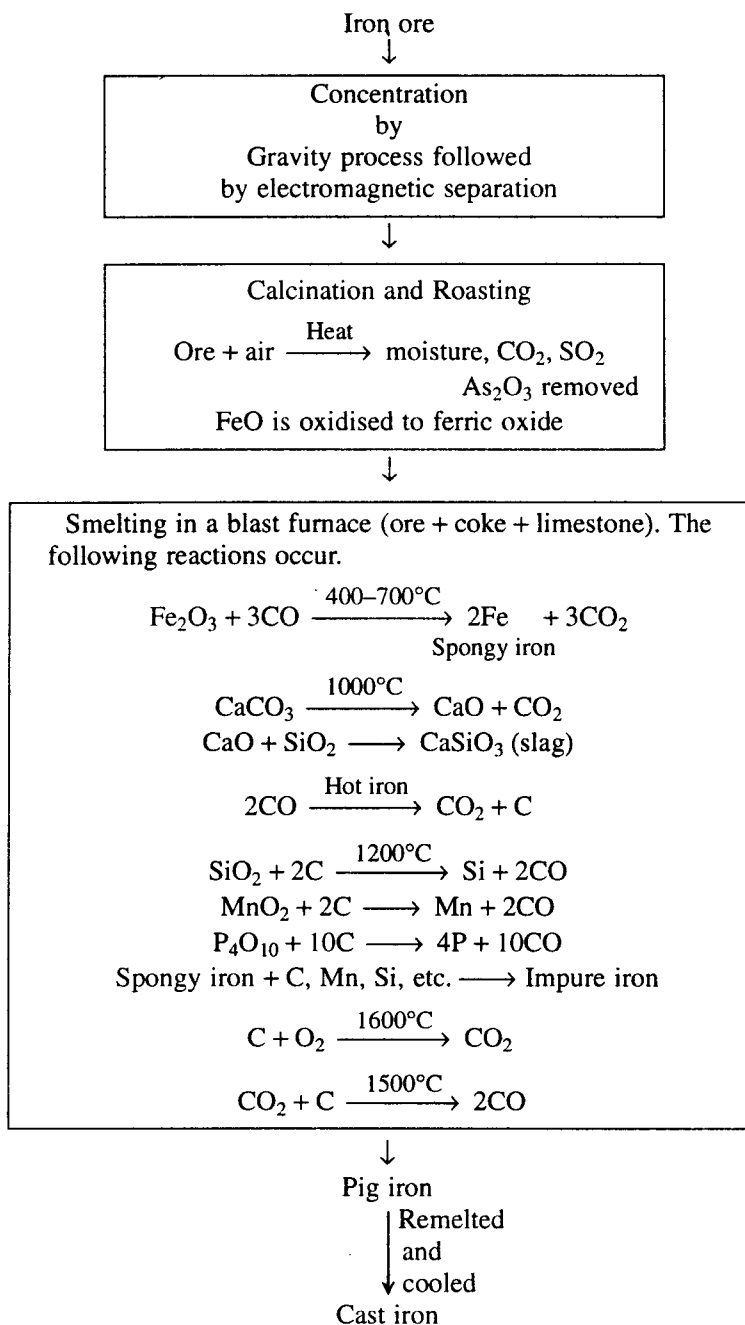

(Fe = 93%; C = 5% and impurities of Mn, P, Si, etc. = 2%)

Iron is extracted from its principal ore, haematite. After the preliminary washing, concentration and roasting, the ore is smelted in the presence of coke and limestone in a blast furnace.

Roasted ore (8 parts) with desulphurized coke (4 parts) and limestone pieces (1 part) is fed into the blast furnace from the top. (Preheated air is blown in through water - jacketed pipes called tuyeres fixed in the lower part of the furnace). There is a temperature gradient as we move from the bottom (temperature about 2000K) to the top (temperature about 500K) of the blast furnace. The blast furnace may be broadly divided into three main parts as described in the following.

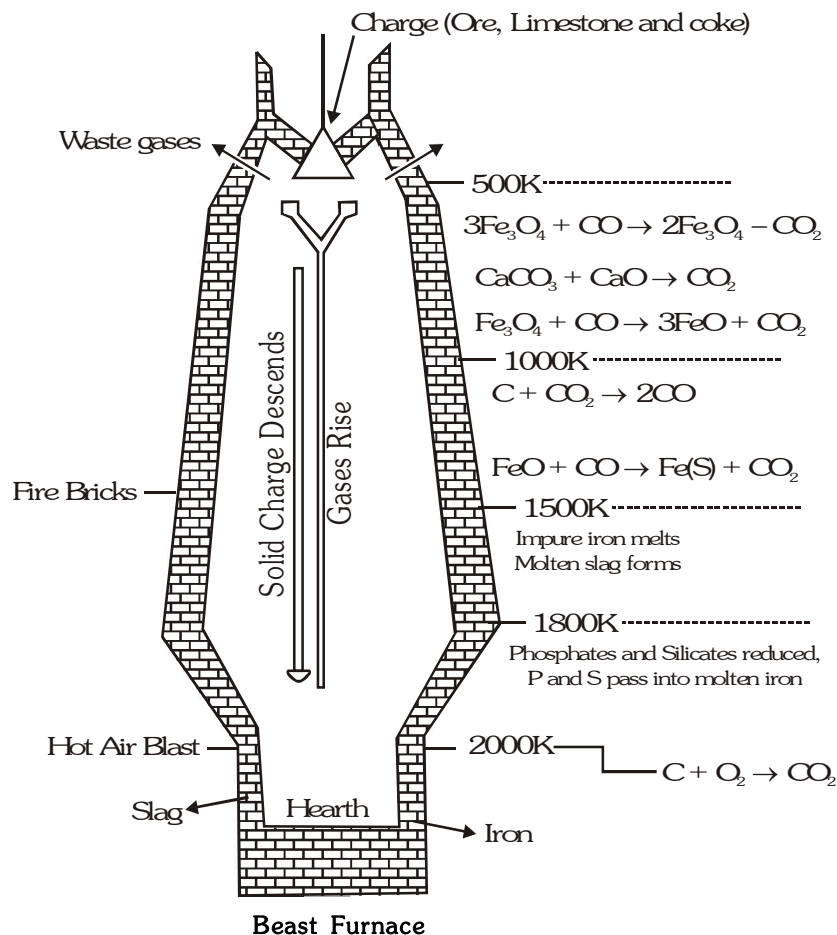

(a) **Zone of fusion**

The lower portion where coke burns and produced carbon dioxide and a lot of heating is known as zone of fusion:



Here the temperature is about 1775 K. A little above this, where temperature is above this, where temperature is about 1475 K - 1575 K, iron coming from above melts.

(b) **Zone of heat absorption**

The middle portion (temperature 1075 K - 1275 K),  $CO_2$  rising up is reduced to CO with the absorption of heat:



In this portion, limestone coming from above is decomposed and the resultant lime (CaO), which acts as flux, combines with silica (present as impurity - gangue) to form calcium silicate (fusible slag) :

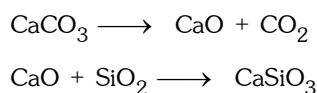

(c) **Zone of reduction**

The upper portion (675K – 975 K) where iron oxide is reduced to spongy iron by carbon monoxide rising up to furnace :

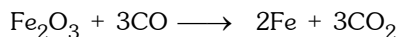

The reduction is believed to take place in stages :

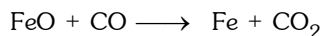
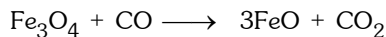
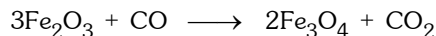

At the bottom of the furnace the molten iron sinks down while above this floats the fusible slag which protects the molten iron from oxidation. These two can be removed from different holes (fig.). Waste gases escaping at the top consists of about 30% CO, 10% CO<sub>2</sub> and the rest nitrogen.

Iron obtained from the blast furnace is known as pig iron.

Pig iron contains about 2–5% carbon as well as other impurities (usually Si, Mn, S and P). Pig iron is converted into cast iron by remelting in a vertical furnace heated by coke. Cast iron expands on solidification and is used for casting various articles. Wrought iron, which is the purest form of iron can be obtained by heating cast iron in a reverberatory furnace lined with iron oxide. Wrought iron contains about 0.2% carbon.

**(D) Manufacture of Steel**

Different methods are used :-

(a) **Bessemer process**

This process is based on the fact that impurities of the pig iron are completely oxidised in presence of hot air blast.

This process involves the use of a large pear-shaped furnace (vessels) called Bessemer converter.

(b) **BOP Method (basic oxygen process)**

The process is carried out in a steel vessel with a refractory lining (usually made of dolomite, CaCO<sub>3</sub>, MgCO<sub>3</sub>). Oxygen gas at about 10 atm pressure and a stream of powdered limestone are fed through a water-cooled lance and discharged above the molten pig iron.

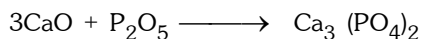
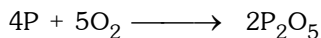
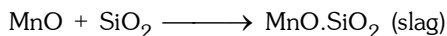
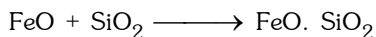
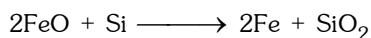
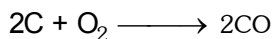

The properties of steel depend on its chemical composition but also on heat treatment. At high temperatures, iron and carbon in steel combine to form iron carbide, Fe<sub>3</sub>C, called cementite :

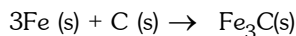

The forward reaction is endothermic, so that the formation of cementite is favoured at high temperatures. When steel containing cementite is cooled slowly, the above equilibrium shifts to the left, and the carbon separates as small particles of graphite, which give the steel a gray colour. If the steel is cooled rapidly, equilibrium is not attained and the carbon remains large in the form of cementite, Fe<sub>3</sub>C. Steel containing

(c) **Heat Treatment of Steel**

**Quenching or hardening**

Steel is heated to red hot temp. and is then cooled suddenly by plunging into either cold water or oil. It makes steel hard and brittle.

**Annealing**

The steel is heated to red hot temp. and then cooled slowly.

It makes steel soft.

**Tempering**

If quenched steel is heated to temp. between 500 to 575 K and then cooled slowly, it becomes quite hard but brittleness disappears. The process is called tempering.

**Surface treatment of steel**

(i) **Nitriding** - Process of heating steel at 1000 K in an atmosphere of  $\text{NH}_3$ .

This gives hard coating of iron nitride on the surface.

(ii) **Case hardening** - Process of giving a thin coating of hardend steel, by heating steel in contact with charcoal followed quenching in oil.

- It is used for axles of railway wagons.

(d) **Types of Iron**

**Cast iron or pig iron**

It is most impure form of Iron and contains the highest proportion of carbon (2.5 - 4 %) along with traces of S, P, Mn and Si. Cast iron contain 2.5 to 4.3 & pig contain 2.5 to 5%.

**Wrought iron (Fibrous iron) or malleable iron**

It is the purest form of iron and contains minimum amount of carbon (0.12 - 0.25%) and less than 5% of other impurities.

**Steel**

It is the most important form of iron and finds extensive applications. As far as carbon content (impurity) is concerned it is mid-way between cast iron and wrought iron, it contains 0.25- 2% carbon.

Thus all the three forms of iron differ in their carbon contents, both iron and steel are obtained from cast iron.

Order of M.P. WI > Steel > CI or PI

**(E) Extraction of Zinc (Zn)**

ORE  $\longrightarrow$  Zin blende or Black jack ( $\text{ZnS}$ )

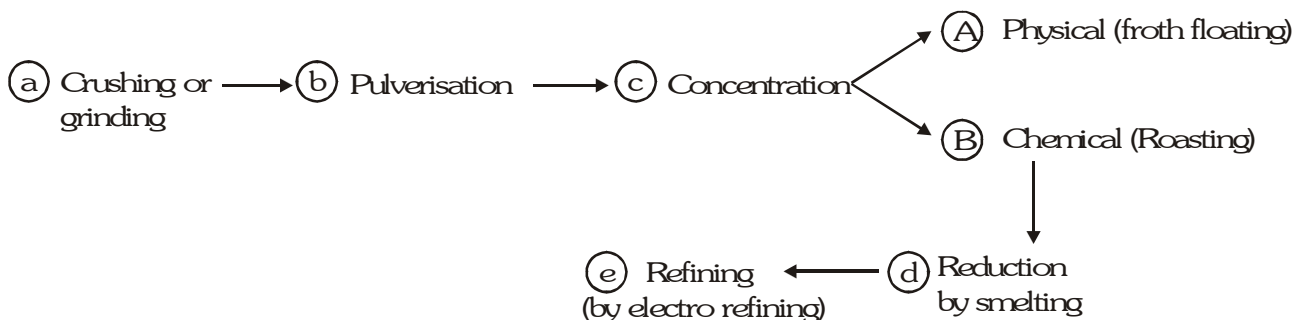

**Uses**

(a) Zn-Cu couple, Zn- Hg, zinc dust etc. are used as reducing agent in organic reactions.

(b) large amounts of zinc are used for galvanizing iron. Zinc is deposited on the surface of iron articles. This process is called galvanization.

## (F) Extraction of Silver and Gold

**Cyanide Process** : Silver and gold are extracted by the cyanide process (Mac Arthur - Forrest process). After the preliminary crushing and concentration by froth floatation process, the ore (crushed auriferous rocks in the case of gold) is leached with dilute (0.4 - 7%) solution of sodium cyanide made alkaline by adding lime kept agitated by a current of air. Silver (or gold) pass into solution as argentocyanide (or aurocyanide) :

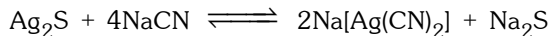

The air blown in remove  $\text{Na}_2\text{S}$  and  $\text{Na}_2\text{S}_2\text{O}_3$  and  $\text{Na}_2\text{SO}_4$  causing the above reaction to proceed to completion.

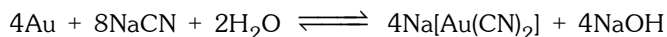
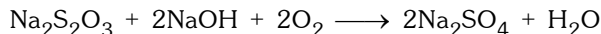
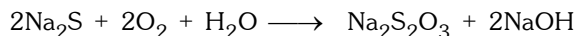

The solution obtained above is filtered and treated with scrap iron or zinc when silver (or gold) get precipitated:

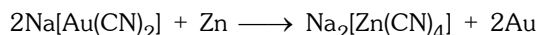
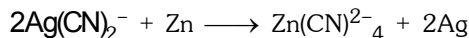

The obtained silver is purified electrolytically (electrolyte : silver nitrate solution containing 1% nitric acid, anode : impure silver, cathode : pure silver). The impurities like zinc and copper pass into the solution while gold falls down as anode mud.

Gold thus obtained is contaminated by zinc which is dissolved out by sulphuric acid. The dried residue of gold is then fused under borax (flux) in graphite crucible and the melted down gold (bullion) which invariably contain silver, is set for refining.

## (G) Extraction of Mercury (Hydragyrum) (Hg)

Short chart of Hg (Hydragyrum) by HgS (Cinnabar or vermilion)

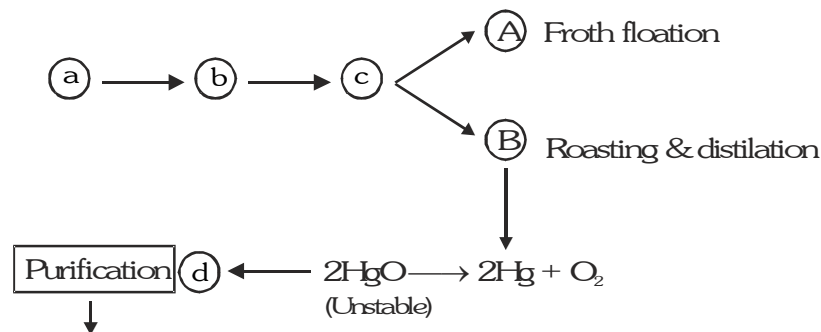

- (a) Pb & Zn remove as oxide.
- (b) Basic metal remove as nitrate in  $\text{HNO}_3$
- (c) Final purification done by vacuum distillation.

## Properties

- (a) It vigorously combines with  $\text{Cl}_2$  slowly with  $\text{Br}_2$  and  $\text{I}_2$ .
- (b) Hot conc.  $\text{H}_2\text{SO}_4$ , dil. & conc.  $\text{HNO}_3$  dissolve it.
- (c) Mercury is acted upon by HI on account of the formation of a complex ion  $(\text{HgI}_4)^{2-}$

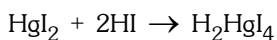
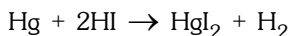

- (d) Hg dissolves many metals and the combinations are called **amalgams**. Au, Ag, Sn, Pb, Mg, Cu, Na, K

## Uses

### Mercury is used :

- (a) In thermometers, barometers and other physical apparatus.
- (b) In the extraction of Ag and Au. In amalgamation process.
- (c) In the form of amalgams as reducing agents.
- (d) In mercury vapour lamps.
- (e) In manufacture of **vermilion** (HgS).

### (H) Extraction of Aluminium

#### Short chart of Al from $\text{Al}_2\text{O}_3 \cdot 2\text{H}_2\text{O}$ (Bauxite)

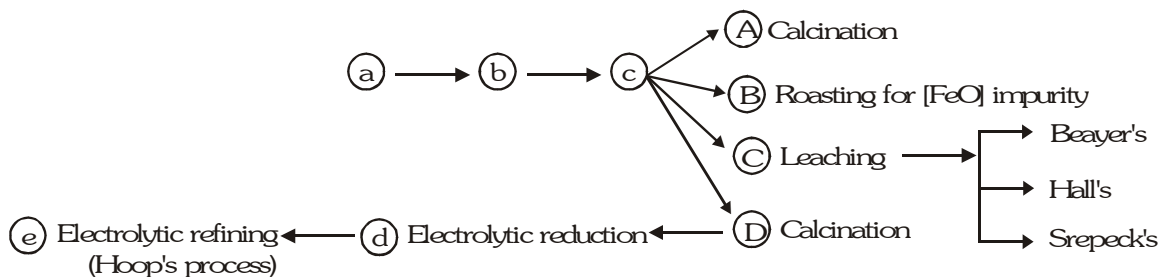

#### BAUXITE



#### Concentration of Bauxite ore

- (a) **Baeyer's process** : (Used for red bauxite in which main impurity is iron oxide)

Bauxite ore  $\xrightarrow{\text{Roasted}}$  as to convert FeO into  $\text{Fe}_2\text{O}_3$

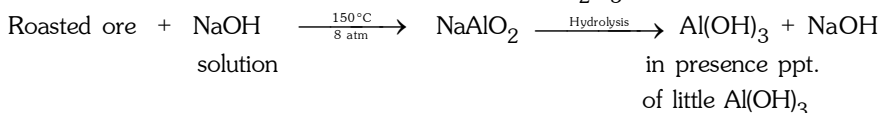

- (b) **Hall's Process** : (Red bauxite)

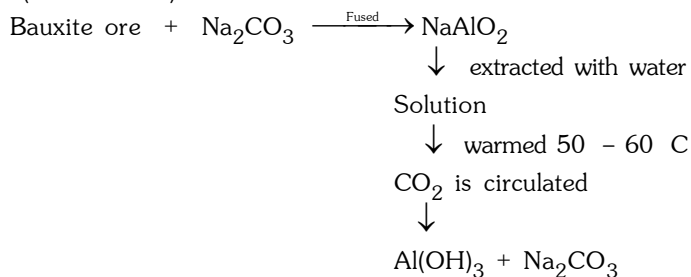

- (c) **Serpeck's process** : (Used for white bauxite in which main impurity is silica)

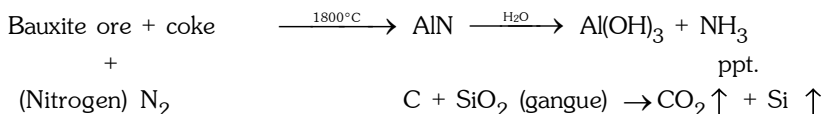

#### CALCINATION

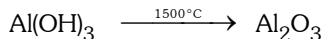

#### Electrolytic Reduction

Electrolyte  $\text{Al}_2\text{O}_3$  dissolved in  $\text{Na}_3\text{AlF}_6$  and  $\text{CaF}_2$

Cathode—Carbon lining

Anode - Graphite rods

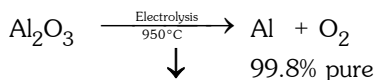

#### Electrolytic Refining

(Hoop's process)



## Important points

- Useful gas  $\text{NH}_3$  is evolved in the leaching of bauxite by serpeck's process.
- In the electrolytic reduction of  $\text{Al}_2\text{O}_3$  cryolite ( $\text{Na}_3\text{AlF}_6$ ) is added along with  $\text{CaF}_2$  (fluorspar) to-
  - decrease m.p. of  $\text{Al}_2\text{O}_3$
  - decrease viscosity of electrolyte ( $\text{CaF}_2$  is used)
  - increase conductivity
- In the electrolytic reduction graphite anode get corrode or finishe due to reaction with  $\text{O}_2$  liberates at anode, hence it had to be changed periodically.
- In the electrolytic refining (4th step) no electrodes are used. In the Hoop's process molten pure Al is used as cathode and molten impure Al is used as anode.
- In the Hoop's process carbon dust is sprayed over molten Al to
  - avoid heat lose
  - minimise metallic lusture (glaze) which is harmful for the eyes.

## (I) Extraction of Magnesium

Magnesium is commonly obtained by the electrolysis of fused magnesium chloride containing a little (25%) sodium chloride and sodium fluoride at  $700^\circ\text{C}$  in an air-tight iron pot which itself serves as the cathode, the anode being a graphite rod which dips into the electrolyte. The anode is surrounded by a perforated porcelain tube for the exit of chlorine. The electrolysis is carried out in the atmosphere of coal gas so as to prevent the attack of atmospheric oxygen and nitrogen on magnesium. Molten magnesium being lighter then the electrolyte, it floats over the fused electrolyte and is withdrawn

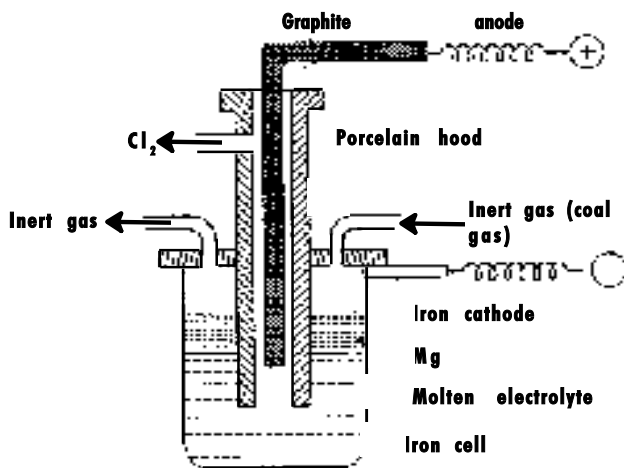
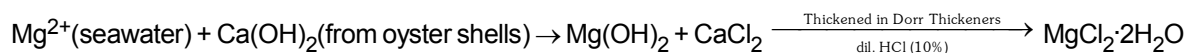

FIG.  
ELECTROLYTIC CELL FOR THE PRODUCTION OF  
MAGNESIUM

In *Dow process*, magnesium is recovered from seawater as magnesium chloride which is then electrolysed using cell described above.

**Dow's Sea Water Process:** Sea water contains 0.13% Mg ions.



**Dow's Natural Brine Process.**

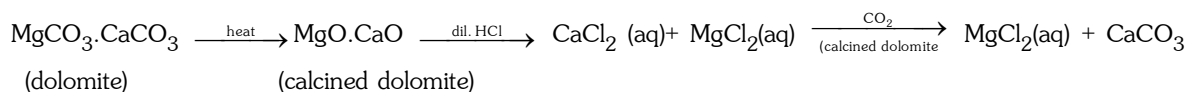

The reaction is :  $\text{CaCl}_2 \cdot \text{MgCl}_2(\text{aq}) + \text{MgO} \cdot \text{CaO} + 2\text{CO}_2 \longrightarrow \text{MgCl}_2(\text{aq}) + 2\text{CaCO}_3 \downarrow$

**Electrolysis:** Ammonium carnallite ( $\text{KCl} \cdot \text{MgCl}_2 \cdot 6\text{H}_2\text{O}$ ) may also be employed as the starting material of magnesium chloride. The cathode may be a layer of molten lead on the floor of the cell and anode may be graphite rods which are suspended above the molten lead. Magnesium liberated at the cathode dissolves in molten lead. The alloy of lead–magnesium is subjected to electrolysis to obtain pure magnesium (electrolyte: fused carnallite, anode : lead–magnesium alloy and cathode–steel rods.)

## 10. THERMODYNAMICS OF REDUCTION PROCESSES (ELLINGHAM DIAGRAM)

The extraction of metals from their oxides using carbon or other metals, and by thermal decomposition, involves a number of points which merit detailed discussion.

For a spontaneous reaction, the free energy change  $\Delta G$  must be negative.

$$\Delta G = \Delta H - T\Delta S$$

$\Delta H$  is the enthalpy change during the reaction,  $T$  is the absolute temperature, and  $\Delta S$  is the change in entropy during the reaction. Consider a reaction such as the formation of an oxide:

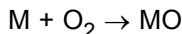

Dioxygen is used up in the course of this reaction. Gases have a more random structure (less ordered) than liquids or solids. Consequently gases have a higher entropy than liquids or solids. In this reaction  $S$  the entropy or randomness decreases, the hence  $\Delta S$  is negative. Thus if the temperature is raised then  $T\Delta S$  becomes more negative. Since  $T\Delta S$  is subtracted in the equation, then  $\Delta G$  becomes less negative. Thus the free energy changed increases with an increase of temperature.

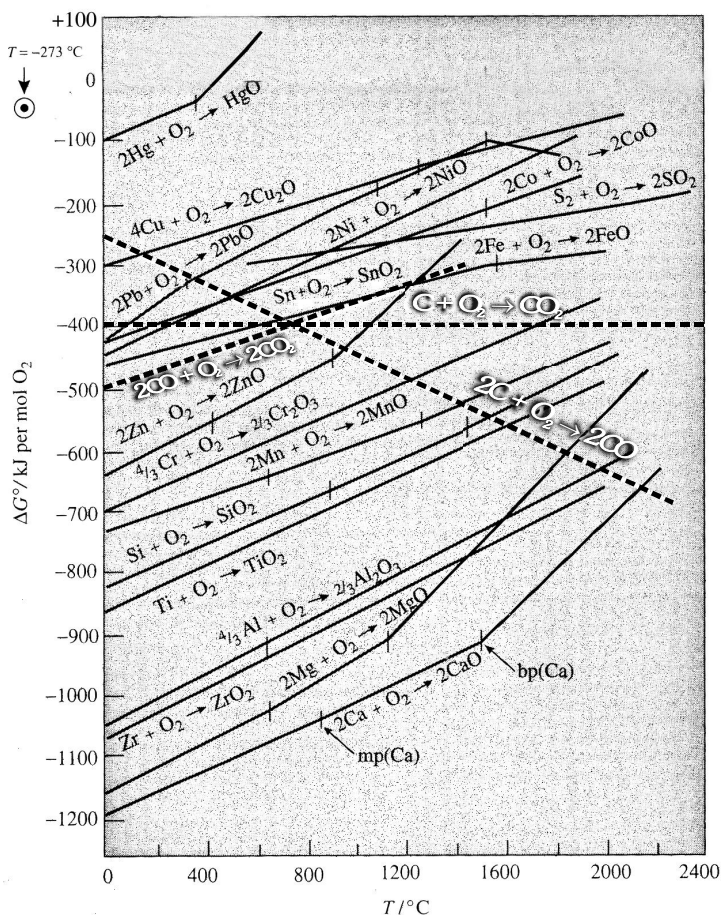

The free energy changes that occur when one gram molecule of a common reactant (in this case dioxygen) is used may be plotted graphically against temperature for a number of reactions of metals of their oxides. This graph is shown in figure and is called an Ellingham diagram (for oxides). Similar diagrams can be produced for one gram molecule of sulphur, giving an Ellingham diagram for sulphides, and similarly for halides.

**The Ellingham diagram for oxides shows several important features:**

- (a) The graph for metal oxide all slope upwards, because the free energy change increases with an increase of temperature as discussed above.
- (b) The free energy changes all follows a straight line unless the materials metal or vaporize.
- (c) When the temperature is raised, a point will be reached where the graph crosses the  $\Delta G = 0$  line. Below this temperature the free energy of formation of the oxide is negative, so the oxide is stable. Above this temperature the free of formation of the oxide is positive, and the oxide becomes unstable, and should decompose into the metal and dioxygen.
- (d) Any metal will reduce the oxide of other metals which lie above it in the Ellingham diagram because the free energy will become more negative by an amount equal to the different between the two graphs at that particular temperature.

**Prob.** Carbon monoxide is more effective reducing agent than carbon below 983 K but above this temperature the reverse is true. How would you explain this?

**Sol.** The two reactions are as :

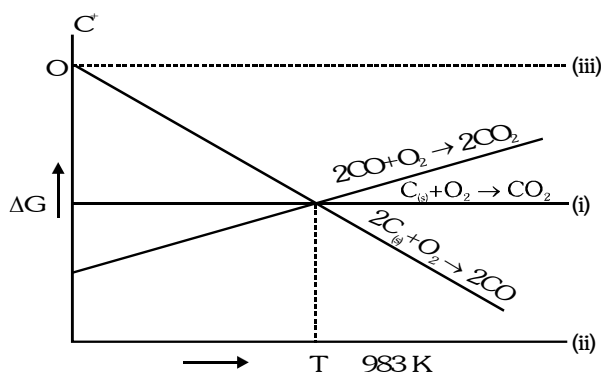

Below 983 K reaction  $2CO + O_2 \longrightarrow 2CO_2$  is more favoured due to more negative  $\Delta G$  value thus CO is better reducing agent than carbon.

Above 983 K, reaction  $2C_{(s)} + O_2 \longrightarrow 2CO$  has more negative  $\Delta G$  than oxidation of CO to  $CO_2$ , so carbon will be better reducing agent.

**Prob.** Al can reduce oxide of Cr but not reduce oxide of Mg and Ca at  $800^\circ C$  explain.

**Sol.** A metal can reduce the oxide of metal placed above in the diagram. Due to more negative free energy. Such that, Al can reduce Cr but not Mg or Ca.

**Prob.** In what condition extraction of Mg is possible by MgO using carbon reduction method.

**Sol.** According to Ellingham diagram reduction of metal oxide with carbon will occur when the accompanying  $\Delta G$  is negative. Such reduction become progressively more feasible the higher the temperature. MgO can only be reduced by carbon at the temperature approximate  $2000^\circ C$ .

Mg was formerly by heating MgO and C to  $2000^\circ C$ , at which temperature C reduces MgO. The gaseous mixture of Mg and CO was then cooled very rapidly to deposit the metal. This 'quenching' or 'shockcooling' was necessary as the reaction is reversible, and if cooled slowly the reaction will come to equilibrium further to the left.

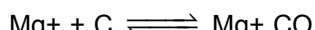

## Limitations of Ellingham Diagram

- (a) The graph simply indicates whether a reaction is possible or not i.e., the tendency of reduction with a reducing agent is indicated. This is so because it is based only on the thermodynamic concepts. It does not say about the kinetics of the reduction process (Cannot answer questions like how fast it could be?).
- (b) The interpretation of  $\Delta G^\ominus$  is based on  $K(\Delta G^\ominus = -RT \ln K)$ . Thus it is presumed that the reactants of products are in equilibrium.

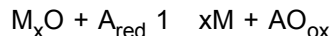

## METALLURGY AT A GLANCE

### FLOW SHEET FOR THE EXTRACTION OF ALUMINIUM

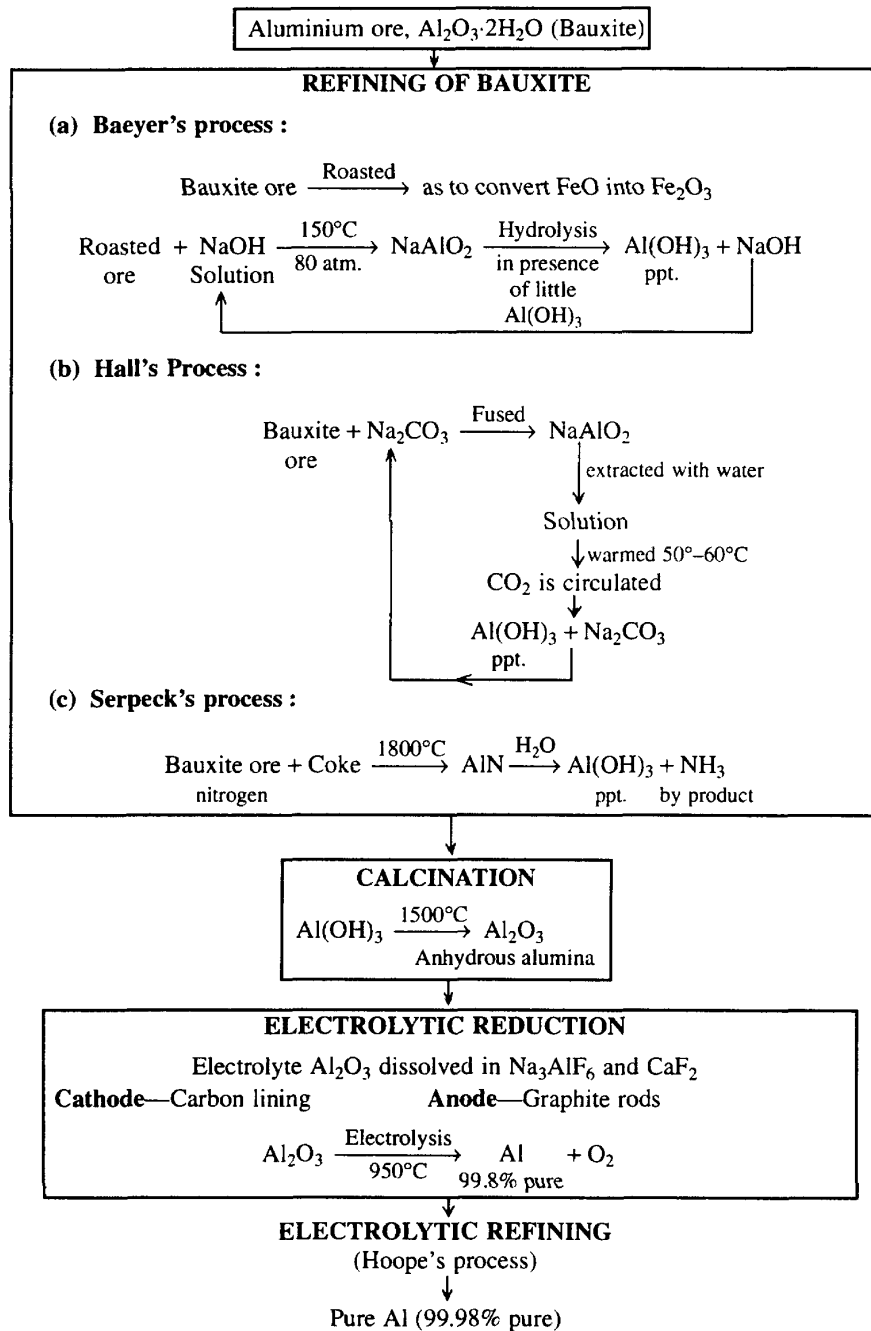

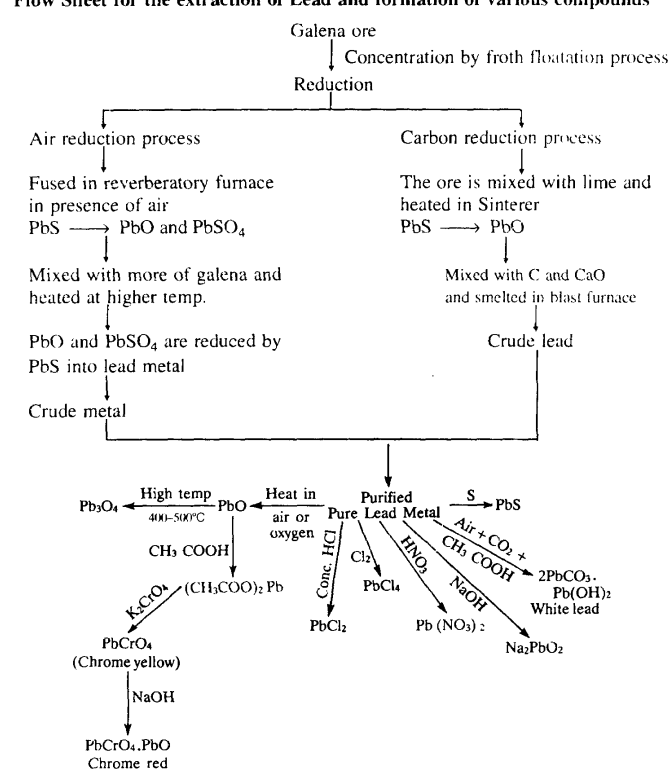

Hot conc.  $H_2SO_4$  dissolves lead with evolution of  $SO_2$  but the reaction becomes lower due to formation of insoluble  $PbSO_4$ .

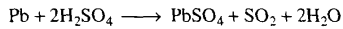

$HNO_3$  is the best solvent for lead. With dil.  $HNO_3$ ,  $NO$  is evolved while with conc.  $HNO_3$ ,  $NO_2$  is liberated.

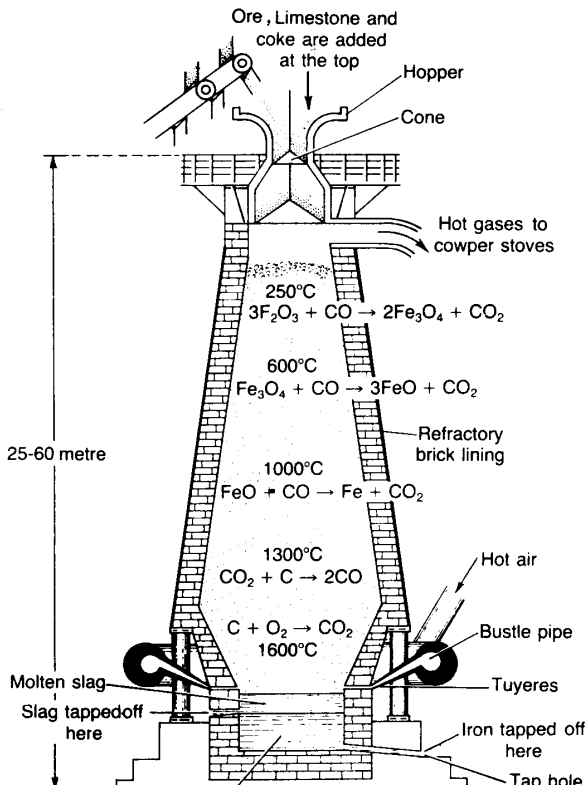
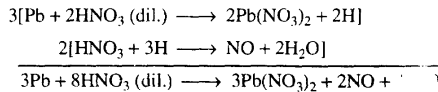

# FLOW SHEET FOR THE EXTRACTION OF COPPER

Copper pyrites  
( $\text{CuFeS}_2$ )

↓  
Crushed and sieved

↓  
Concentration by froth floatation  
Powdered ore + water + pine oil + air  $\longrightarrow$  sulphide ore in the froth

↓  
Roasting in reverberatory furnace in presence of air

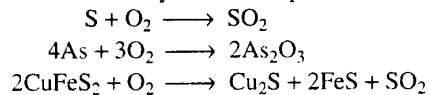

↓  
Silica + coke  $\longrightarrow$  Roasted ore

↓  
Smelting in blast furnace in presence of air

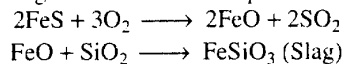

↓  
Silica  $\longrightarrow$  Matte ( $\text{Cu}_2\text{S}$ ,  $\text{FeS}$ )

↓  
Bessemerisation in bessemer converter in presence of air

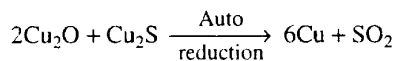
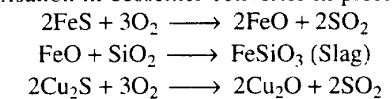

↓  
Blister copper (98% Cu + 2% impurities)

↓  
Electrolytic refining

Anode—Impure copper plates  
Cathode—Pure copper plates  
Electrolyte— $\text{CuSO}_4$  soln. +  $\text{H}_2\text{SO}_4$   
Pure copper deposited at cathode

↓  
Pure copper  
(99.6–99.9%)

# FLOW SHEET FOR THE EXTRACTION OF SILVER

Silver ore  
(Argentite)

## CONCENTRATION BY FROTH FLOTATION PROCESS

Powdered ore + Water + Pine oil + Air  $\longrightarrow$   
Froth carrying sulphide particles

## CYANIDATION

Concentrated ore + NaCN solution (0.4–0.6%) + Air

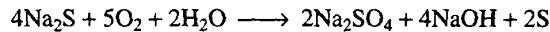
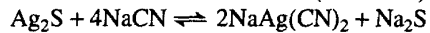

$\downarrow$  Filtration

## PRECIPITATION OF SILVER WITH ZINC

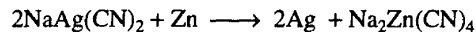

Black ppt.

Black ppt. of Ag +  $\text{KNO}_3 \xrightarrow{\text{Fuse}}$  Compact mass  
(Silver metal)

## ELECTROLYTIC REFINING

Anode : Impure silver

Cathode : Pure silver plate

Electrolyte :  $\text{AgNO}_3$  solution +  $\text{HNO}_3$

Pure silver deposited on the cathode

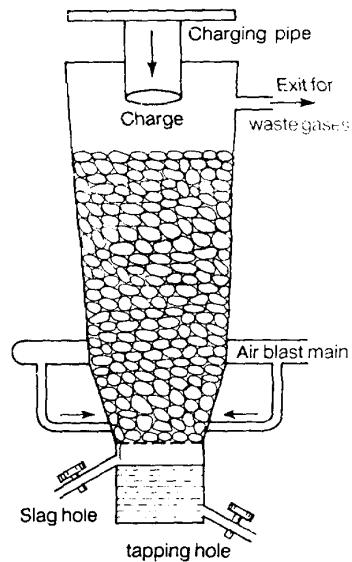
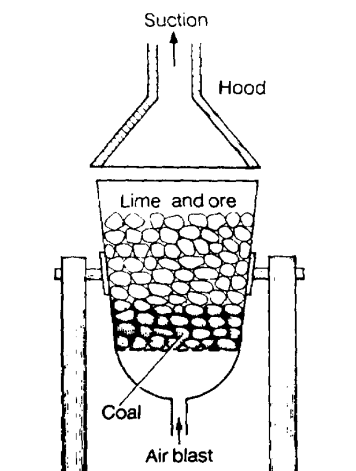
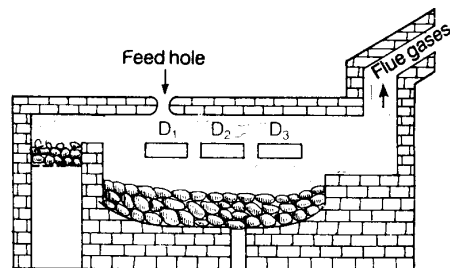
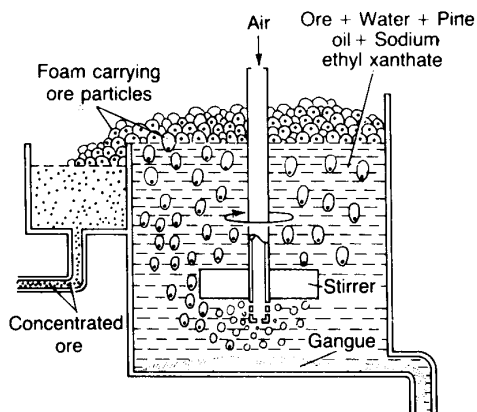

# APPENDIX

---

## SOME IMPORTANT COMPOUND AND THEIR FORMULEA

Lunar caustic (Highly photo sensensitive)	$\text{AgNO}_3$
Monozite	$\text{ThO}_2$
Calomal	$\text{Hg}_2\text{Cl}_2$
Ilmanite	$\text{TiO}_2$
Corrosive sublimate (does not give chromyl chloride test)	$\text{HgCl}_2$
Type metal	$\text{Pb}+\text{Sn}+\text{Sb}$
Constantan	$\text{Cu}(60\%) +\text{Ni} (40\%)$
Litharge	$\text{PbO}$
Red Lead (OR) Sindhur	$\text{Pb}_3\text{O}_4$
Butter of tin	$\text{SnCl}_4 \cdot 5\text{H}_2\text{O}$
Spelter	(Impure Zn during extraction of Zn) Crude zinc metal called spelter which contain nonfusible impurities and the impurities of Pb, Fe, Cd.
Green vitrol	$\text{FeSO}_4 \cdot 7\text{H}_2\text{O}$
Blue vitrol	$\text{CuSO}_4 \cdot 5\text{H}_2\text{O}$
White vitrol	$\text{ZnSO}_4 \cdot 7\text{H}_2\text{O}$
Lithopone	$\text{BaSO}_4 + \text{ZnS}$
Nessler Reagent in basic medium	$\text{K}_2\text{HgI}_4$
Mohr salt (ferrous Ammonium sulphate)	$\text{FeSO}_4 (\text{NH}_3)_2\text{SO}_4 \cdot 6\text{H}_2\text{O}$
Ignition mixture	$\text{Mg powder} + \text{BaO}_2$
Fusion mixture	$\text{Na}_2\text{CO}_3 + \text{K}_2\text{CO}_3$
Freezing mixture	NaCl is used with ice
Electron	$\text{Mg} (95\%) + \text{Zn} (5\%)$ used in aircraft

---